

CURVY AM[®]

SHOE SIZE	WIDTH	HEIGHT	SIZE NAME	SIZE
38	42	44	XX-WIDE/SHORT	XXW/S
38	42	46	XX-WIDE/NORMAL	XXW/N
39	42	44	XX-WIDE/SHORT	XXW/S
39	42	46	XX-WIDE/NORMAL	XXW/N
39	42	48	XX-WIDE/LONG	XXW/L
40	42	44	XX-WIDE/SHORT	XXW/S
40	42	46	XX-WIDE/NORMAL	XXW/N
40	42	48	XX-WIDE/LONG	XXW/L
40	42	50	XX-WIDE/X-LONG	XXW/XL
41	42	46	XX-WIDE/NORMAL	XXW/N
41	42	48	XX-WIDE/LONG	XXW/L
41	42	50	XX-WIDE/X-LONG	XXW/XL
42	42	46	XX-WIDE/NORMAL	XXW/N
42	42	48	XX-WIDE/LONG	XXW/L
42	42	50	XX-WIDE/X-LONG	XXW/XL
INSERTS	WIDTH	HEIGHT	SIZE NAME	
2-CM Inserts	2	44	2/44	
	2	46	2/46	
	2	48	2/48	
	2	50	2/50	
4-CM Inserts	4	44	4/44	
	4	46	4/46	
	4	48	4/48	
	4	50	4/50	
6-CM Inserts	6	44	6/44	
	6	46	6/46	
	6	48	6/48	
	6	50	6/50	
8-CM Inserts	8	44	8/44	
	8	46	8/46	
	8	48	8/48	
	8	50	8/50	
10-CM Inserts	10	44	10/44	
	10	46	10/46	
	10	48	10/48	
	10	50	10/50	

Please check our measurement guide, if necessary.

SUEDWIND FOOTWEAR

HOW TO MEASURE OUR TALL BOOTS AND CHAPS

- Please sit in a chair with your knees at a 90 degree angle towards the floor.
- Wear your usual riding breeches and socks (no shoes).
- Have someone else measure your calves, if possible.

Measurement:

A. How to measure your calf WIDTH:

The calf needs to be measured at the widest part.

B. How to measure your calf HEIGHT:

The height must be measured barefoot from the bottom of the heel up to the back of the knee (sitting on a chair).

Example:

You measure 35 cm in width and 46 cm in height.
Which size do you have to pick?

Width $35 - 1 \text{ cm} = 34 \text{ cm}$

Height $46 + 2 \text{ cm} = 48 \text{ cm}$

The correct size to pick is 34/48.

Tip:

- As tall boots and chaps tend to compress a few centimeters when in use, you should add 2 cm (as explained above).
- The shaft must fit tight. The leather will stretch at least 1 cm in width when use.
- Not all tall boots and chaps measure the same. Please check the remarks in the size chart per style.

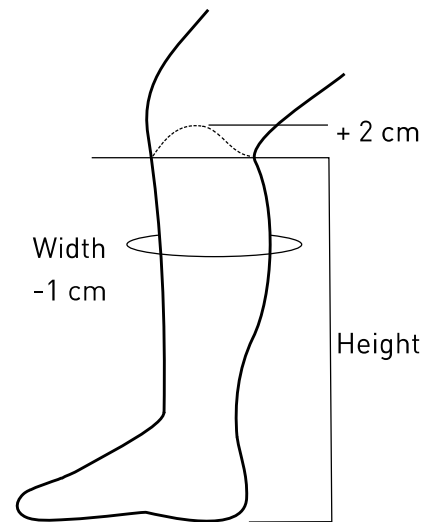

SUEDWIND FOOTWEAR

FFIND THE RIGHT SHOE & BOOT SIZE

1. Stand barefoot on a piece of white paper with your heel and the paper against the wall.

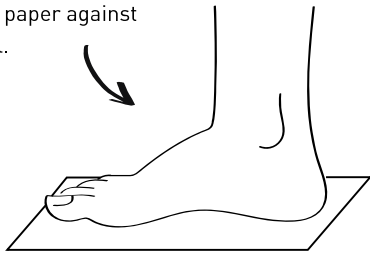

2. Draw your foot shape with a pencil from the longest toe to the heel.

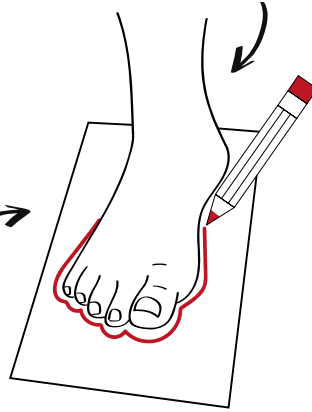

3. Draw both of your feet in order to use the longer foot for the following step 4.

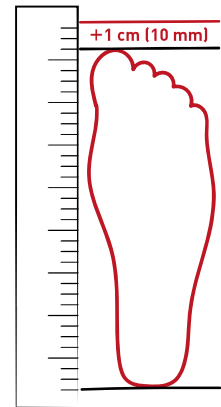

4. Measure your drawing from the heel to the longest toe (the heel marks the end of the sheet).

Detailed explanation:

1. To find the right shoe size, you first need to measure your feet. To do so, please stand barefoot on a piece of white paper with your heel against the wall. It is important that the heel and edge of the paper touch the wall and thus start at the same point.
2. Draw your foot shape with a pencil (see picture).
3. After you have drawn both your feet, you can measure their length on the paper – from the longest toe to the heel (the heel marks the end of the sheet). In order to find the correct inner length of our shoes, you have to add (at least) 1 Centimeter to your foot length.
4. For example, if your longer foot measures 22.8 CM, you have to calculate $22.8 + 1.0$. This results in an inner shoe size of 23.8 CM. Then, refer to our „Conversion Chart“ and find the correct shoe size under „JPN“, in this case it would be size EU 38 (24.0 CM).

Important: If you are unsure which size to take, always choose the next larger size.

Conclusion:

Every foot is different. The length of your feet can be determined quickly, but depending on the position of the foot, the width of the foot, the instep height or the shape of your toes, it can be difficult to find the right size and fit. The rule of thumb for our shoes is, that you have to add 10 – 15 millimeters (1.0 – 1.5 CM) to your foot length in order to find the right shoe size.

In the end, you always have to try shoes on to make sure that you feel comfortable.